

MAAOA/215-Series

TOGGLE SWITCHES

The MAAOA/215-Series toggle switches are single pole, AC rated at 20 amps and 125 VAC. These switches are snap-in mounted, with a phenolic toggle and base, and are suitable for high ambient temperature applications.



Product Highlights:

- High temperature Phenolic base and toggle
- Ratings to 125VAC
- Optional embossed On-Off legend
- Choice of screw, .250 Tab or integrated wire lead connections

Typical Applications:

- Coffee Makers
- Food Warmers



Carling Technologies®
Innovative Designs. Powerful Solutions.

Techna

www.techna.co.uk

Dielectric Strength

UL/CSA: 1000V - live to dead metal parts & opposite polarity

Electrical Life

25,000 cycles

Operating Temperature

32°F to 185°F (0°C to 85°C)

MAAOA - **BL** / **ON-OFF**

¹
Base Part Number

²
Color

³
Legend

1 BASE PART NUMBER: SERIES / CIRCUITRY / RATING / TERMINATION

10A 250 VAC, 20A 125 VAC, 1/2 HP 125-250 VAC

| | .250 Tabs | Screw Terms. | Wire Leads |
|-------------|-----------|--------------|------------|
| Single Pole | | | |
| On-Off | MAAOA | 215 | 215A |
| (On)-Off | MM-021 | - | - |

2 BASE & ACTUATOR COLOR

| | | | |
|----|-------|----|-------|
| BL | Black | BN | Brown |
|----|-------|----|-------|

3 LEGEND¹

On-Off

Notes:

Panel Cut-Out recommendations: For sheet metal panels, switch must enter panel in same direction as the punch. (Burr on bottom.) Test cut hole in actual material.

¹ Imprinting is available. ON-OFF legend is not standard and must be specified after color. If not specified, switch will be manufactured with no legend.

() Indicates momentary function.

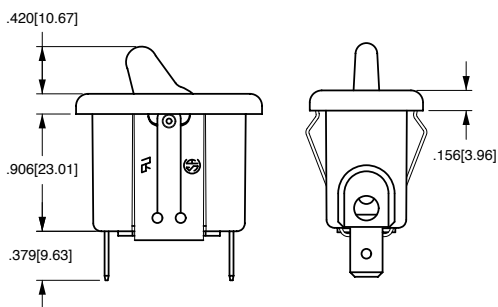

| | | |
|----------------------|-------------------|--|
| | | |
| .250 TAB (Q.C.) | SCREW (ASSEMBLED) | INTEGRATED WIRE LEAD (no exposed conductors) |
| TERMINAL TYPE | | |

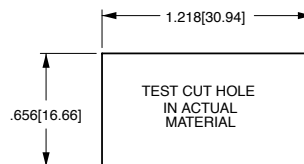

MOUNTING HOLE
Panel Thickness: .030 [0.762] min - .090 [2.28] max.
Specific cutout dimension range dependent on panel thickness and material.

*Manufacturer reserves the right to change product specification without prior notice.